

"WIDE FINE" Moulder

Model WFS

Easier operation, cleaning & maintenance!!!

- Variable speed change by inverter for belt speed (geared with roller).
- Design for higher sanitation and easier maintenance enable easy replacement of the belt.
- Sanitary stainless cover



"Return Gap" mechanism for pressure board. Pressure board height is indicated with figure for easier setting.



Rear cover is fully opened for easier maintenance. Equipped with a pulling-out type catch pan underneath.

"WIDE FINE" Moulder

Model WFS

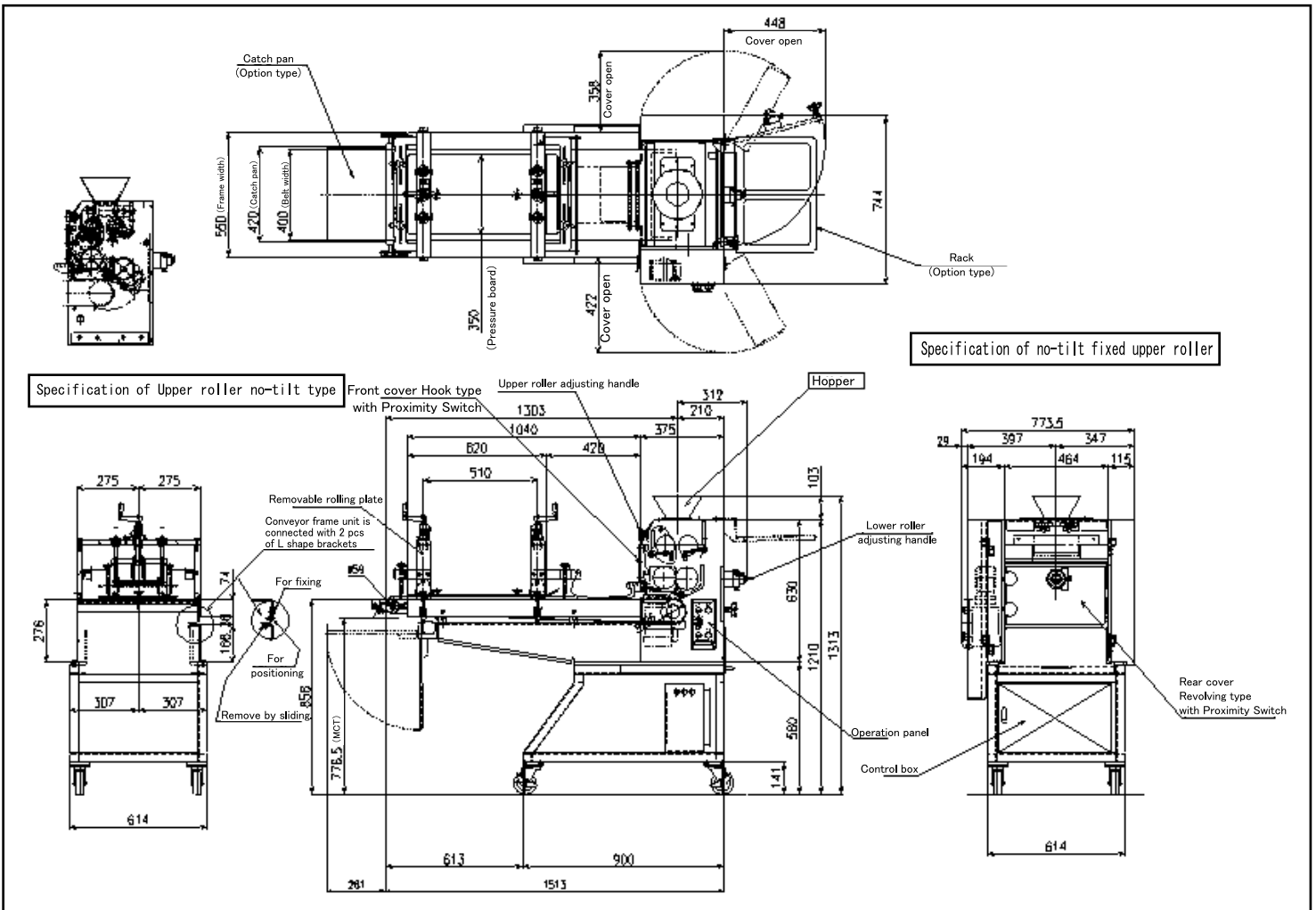

■ Specifications

Capacity	3,000pcs/h in case of 230g 4,500pcs/h in case of 30g
Dough weight	30~230g
Roller Diameter	Upper φ85(Polyacetal) Bottom φ100(Teflon)
Roller clearance	Upper 9 - 14 Lower 1 - 9mm
Roller speed	27.5~55m/min
Pressure board size	W 350 X L 680mm
Pressure board height adjustment range	10~50mm
Width plate adjusting range	100~330mm
Motor	For Main drive motor (Standard) 4P 0.4kW
Machine weight	Approx. 350kg

■ Optional items

- SUS made base frame / control box
- Pressure board also available for roll product
- Detachable bottom plate of pressure board
- Container rack at infeed
- Discharge receiving pan
- Discharge chute
- Digital indication of roller clearance



Note) Specifications and dimensions may be subject to change without prior notice.
 Note) Supply voltage is in accordance with the one in the country machine is used.
 Transformer might be needed according to the specifications.

OSHIKIRI MACHINERY LTD.

<https://www.oshikiri.com/>

4, Kirihara-cho, Fujisawa-shi, Kanagawa, 252-0811 Japan
 Phone: 0466-44-6184 Fax: 0466-44-6187 E-mail: intl@oshikiri.com

Oshikiri Corporation of America

10425 Drummond Road, Philadelphia, Pennsylvania 19154-3898
 Phone: 215-637-6005 Fax: 215-637-6041 E-mail: oshikiri-production@msn.com