

Model RSA

Reverse Sheeter

Easy-to-attach/detach scraper and easy cleaning
The belt with the surface layer made of urethane resin is used.
No meandering and hygienic

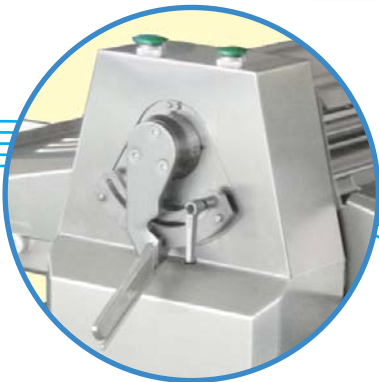

Can be folded up into a compact size!
Easy to move with casters.

Light handle operation is achieved.



OSHIKIRI

Reverse Sheeter

Model RSA

■ Dimensional Drawing

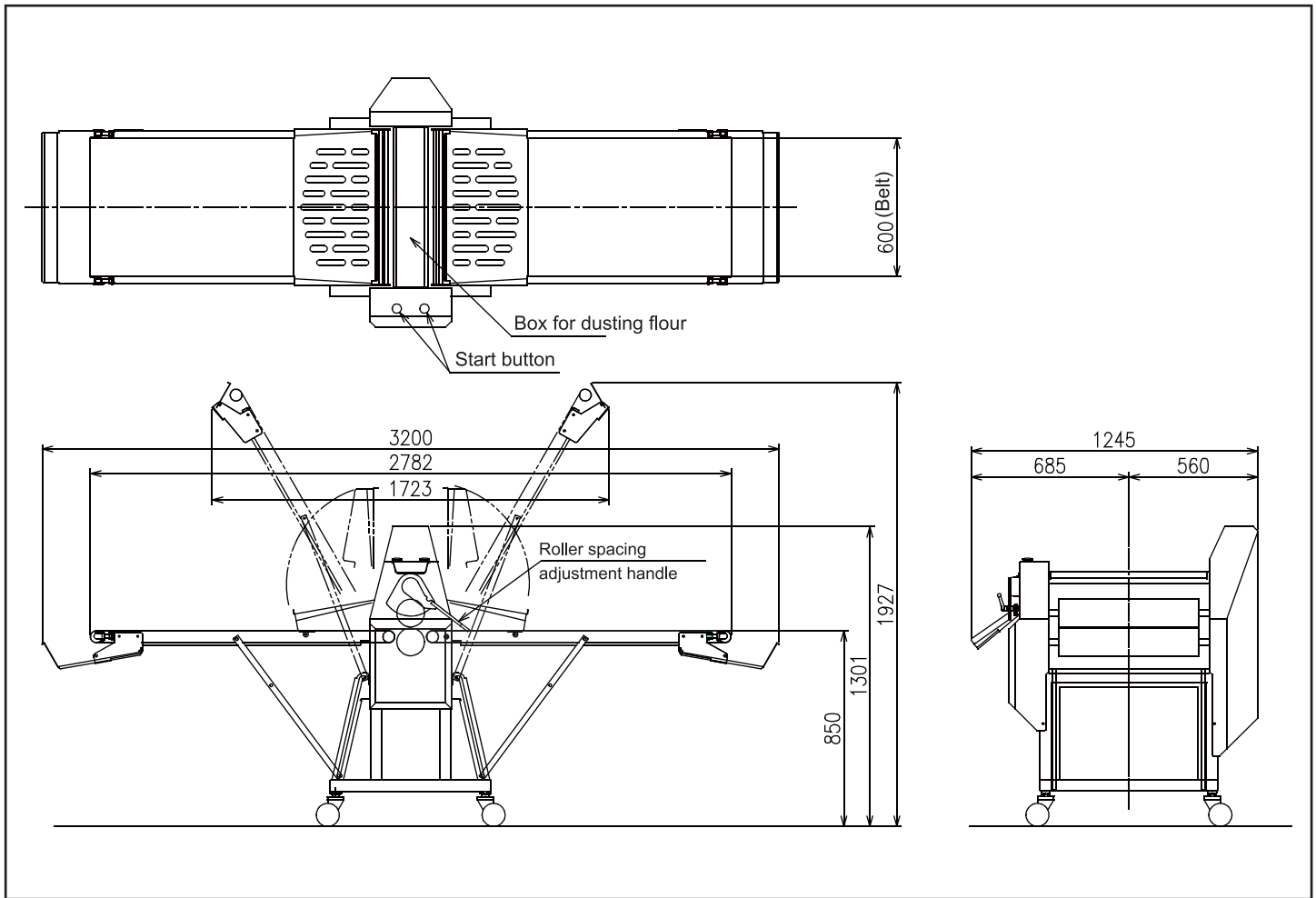

■ Specifications

Reverse Sheeter Model RSA		
Range of roller clearance	1.5~45mm	Manual
Roller speed	36m/min	
Power Source	AC200V 3Phases	
Capacitance	Sheeter roller	0.4kW×2
	Belt conveyer	0.2kW×2
	Total	1.2kW

Note) Specifications and dimensions may be subject to change without prior notice.

Note) Supply voltage is in accordance with the one in the country machine is used.
Transformer might be needed according to the specifications.

OSHIKIRI MACHINERY LTD.

<https://www.oshikiri.com/>

4, Kirihara-cho, Fujisawa-shi, Kanagawa, 252-0811 Japan
Phone: 0466-44-6184 Fax: 0466-44-6187 E-mail: intl@oshikiri.com

Oshikiri Corporation of America

10425 Drummond Road, Philadelphia, Pennsylvania 19154-3898
Phone: 215-637-6005 Fax: 215-637-6041 E-mail: oshikiri-production@msn.com