

Model MKC

# Cross Grain Moulder

Applicable for larger dough pieces

Optional motor driven pressure board enables gentle and stable rolling of dough. Easy adjustable height with digital indication. Lift-up mechanism saves dismantling time for cleaning.

Teflon rollers with larger diameter results in sheeting with less damage to dough. The machine stops upon opening the front & rear covers.

Flour duster runs/stops by signals from dough detector. It stops upon opening the cover.

Transfer plate diverts traveling direction. Lift-up mechanism saves dismantling time for cleaning.

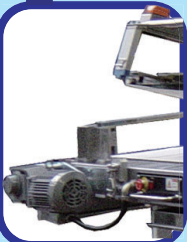

Midair shaft motor eliminated base frame and facilitated accessibility to pan conveyor. It can be mounted on either side of the conveyor.

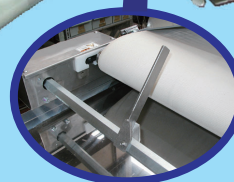

Optional Quick-Release device loosens the belt by one-touch. Easy cleaning inside of the belt.

 **OSHIKIRI**

# Cross Grain Moulder

# Model MKC

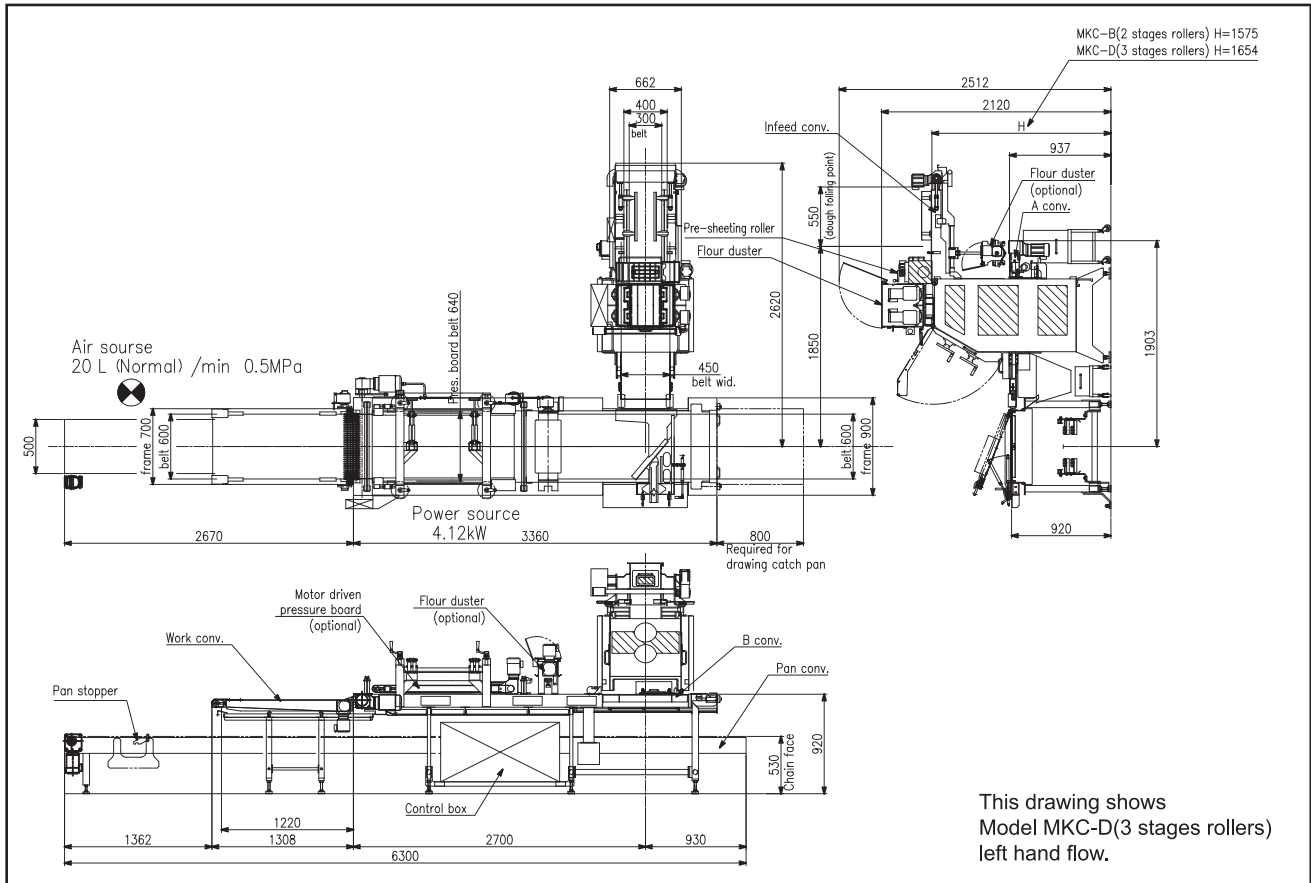

## ■Sheeting section

Capacity	4000pcs/h (520g dough)	4500pcs/h (360g dough)	
Dough weight	220-520g		
Rollers	1st roller	2nd roller	3rd roller
Diameter (mm)	100	130	150
Length (mm)	340	400	400
Clearance (mm)	8-16(fixed)	3-11(adjustable)	1-9(adjustable)
Speed (m/min)	53-80	73-112	92-140
Material	Duracon	Teflon	
A conveyor	Width:450mm Speed:70~140m/min		
Infeed conveyor	Width:300mm Speed:30m/min(60Hz)		
Pre-sheeting roller	Dia.φ102 Speed:24m/min(60Hz) Material :Duracon		
Motor output			
Roller	1.5kW		
A conveyor	0.4kW		
Infeed conveyor	0.1kW		
Pre-sheeting roller	0.1kW		
Flour Duster	0.04kW×3		
Flour Duster for A belt	0.09kW(Optional)		

## ■Pressing section

B conveyor	Width:600mm Speed:20-86m/min
Pressure board	Width:640mm Speed:3.8-11.3m/min
Motor driven pressure board	Optional
Work conveyor	Width:600mm Speed:5m/min(60Hz)
Case dimensions	L:300-380 W:125 H:125-140mm
Motor output	
Flour Duster for B belt	0.1kW(Optional)
B conveyor	0.75kW
Pressure board	0.2kW(Optional)
Work conveyor	0.4kW
Case conveyor	0.4kW
Machine weight	Approx.2300kg
Power source	AC200V 3Phases 4.12kW

Note) Specifications and dimensions may be subject to change without prior notice.

Note) Supply voltage is in accordance with the one in the country machine is used.  
Transformer might be needed according to the specifications.

**OSHIKIRI MACHINERY LTD.** <https://www.oshikiri.com/>

4, Kirihara-cho, Fujisawa-shi, Kanagawa, 252-0811 Japan  
Phone: 0466-44-6184 Fax: 0466-44-6187 E-mail: intl@oshikiri.com

Oshikiri Corporation of America  
10425 Drummond Road, Philadelphia, Pennsylvania 19154-3898  
Phone: 215-637-6005 Fax: 215-637-6041 E-mail: oshikiri-production@msn.com

22.10.03 OSHIKIRI P-082-6



OSHIKIRI Website