

Model **LSS**

# ***Loaf Separator for one pound***

*Separate sliced three pounds loaf to one pound automatically  
Improve sanitation · operation · maintenance more!*



Model: LSS

Model: BSS

◆The drive of conveying is applied to servo actuator smooth and proper movement and quit running sound.

◆Easy cleaning as top conveying face is full open.



## Dimensional Drawing

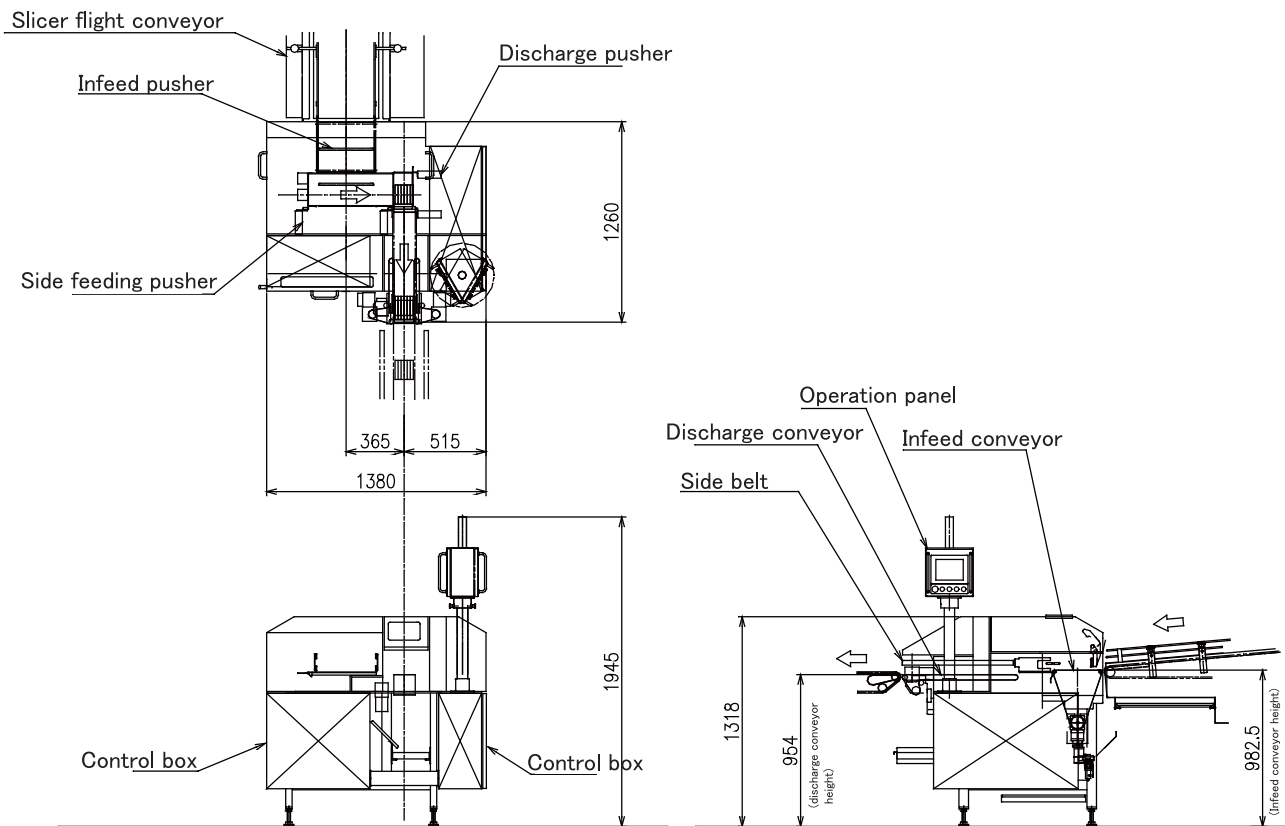

## Specifications

Capacity	MAX 60 packs/min for one pound
Operation	Touch panel type (preset product changeable)
Air Required	100NL/min
Shipping Weight	Approx. 500kg
Power Source	AC200V 3Phases 1kW

Note) Specifications and dimensions may be subject to change without prior notice.

Note) Supply voltage is in accordance with the one in the country machine is used.

Transformer might be needed according to the specifications.

## OSHIKIRI MACHINERY LTD.

<https://www.oshikiri.com/>

4, Kiri-hara-cho, Fujisawa-shi, Kanagawa, 252-0811 Japan

Phone: 0466-44-6184 Fax: 0466-44-6187 E-mail: intl@oshikiri.com

Oshikiri Corporation of America

10425 Drummond Road, Philadelphia, Pennsylvania 19154-3898

Phone: 215-637-6005 Fax: 215-637-6041 E-mail: oshikiri-production@msn.com

19.07.22 OSHIKIRI P-218-2