

Model DQS Dough Divider

Easy maintenance!



Speed Change by VFD Control

The speeds of 1st conveyor and strokes can be changed by VFD control easily at operation panel.

Oil Dripping Lubrication

Oil dripping lubrication to each sliding section can be adjusted by handle.
Oil tank is made of stainless steel and removable for cleaning.

Removal Conveyor Belt

Loosen the conveyor belt by lever.
The belts are made of resin and back side can be cleaned easily.



Rotating Lower Hopper

Dough chamber is cleaned easily.

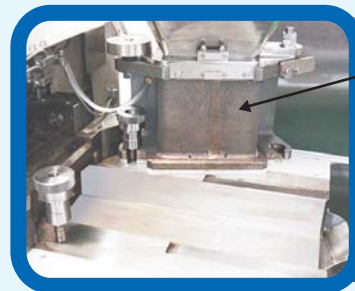

Lower Hopper

See-through Cover

Eye inspection and dirt can be done without removing cover.

Independent Electrical Control Panel

Remove the connector to separate the machine.
Move it easily when making maintenance.

 **OSHIKIRI**

Dough Divider

Model DQS

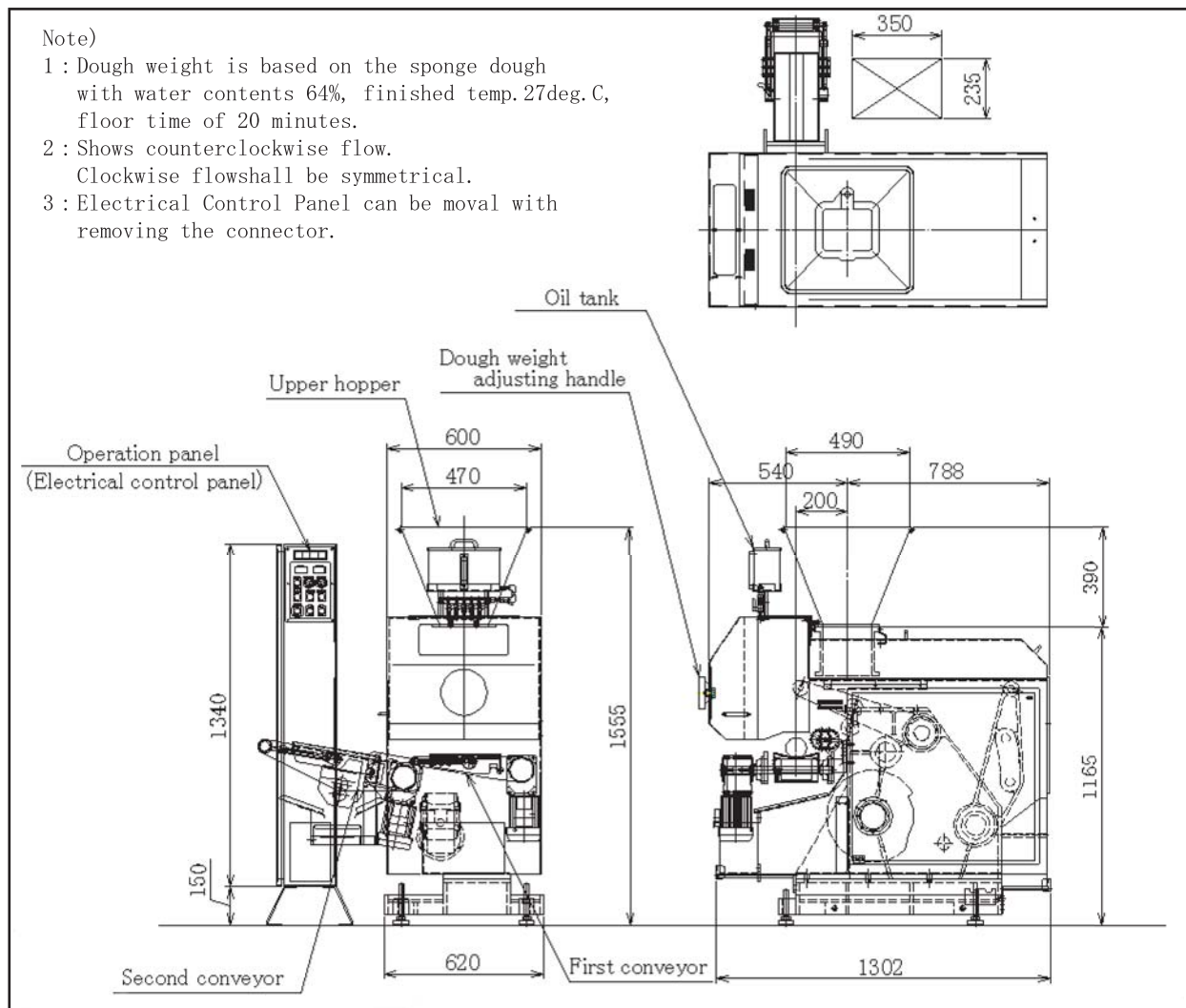

■ Specifications

Model	DQS2	DQS2/4 (OPTIONAL)	
No. of pockets	2	2	4
Dividing weight	25 to 230g	25 to 230g	20 to 80g
No. of strokes	10~25st/min		
Capacity	1,200~3,000pcs/h	1,200~3,000pcs/h	2,400~6,000pcs/h
Hopper capacity	45L		
Power Source	AC200V 3Phases		
Motor output	Main drive 1.5kW Conveyor drive 0.2kW × 2		
Machine weight	Approx. 800kg		

Note) Specifications and dimensions are subject to change without prior notice.

Note) Transformer might be needed depending upon the specifications.

OSHIKIRI MACHINERY LTD.

<https://www.oshikiri.com/>

4, Kirihara-cho, Fujisawa-shi, Kanagawa, 252-0811 Japan
 Phone: 0466-44-6184 Fax: 0466-44-6187 E-mail: intl@oshikiri.com

Oshikiri Corporation of America

10425 Drummond Road, Philadelphia, Pennsylvania 19154-3898
 Phone: 215-637-6005 Fax: 215-637-6041 E-mail: oshikiri-production@msn.com



OSHIKIRI Website