

SERVO DIVIDER Model DKX1

The Next Generation Divider X series

PRECISION

Changeable Pressure feed to dough divides dough with optimum pressure.
Sucking stroke of main ram and knife changeable.
Independent drives for division head, knife and main ram.
Flexible setting of dividing mode and timing of each component with a basic program in compliance with dough weight and machine speed.

LONG LIFE

Replaceable front & bottom plate of dough chamber (i.e. sliding part) just by screwing. Division head does not contact with sliding parts.
Replaceable dough chamber just by screwing.
Lubricating amount adjustable point by point for auto-lubricator.



SHIKIRI MACHINERY LTD.

SERVO DIVIDER Model DKX1

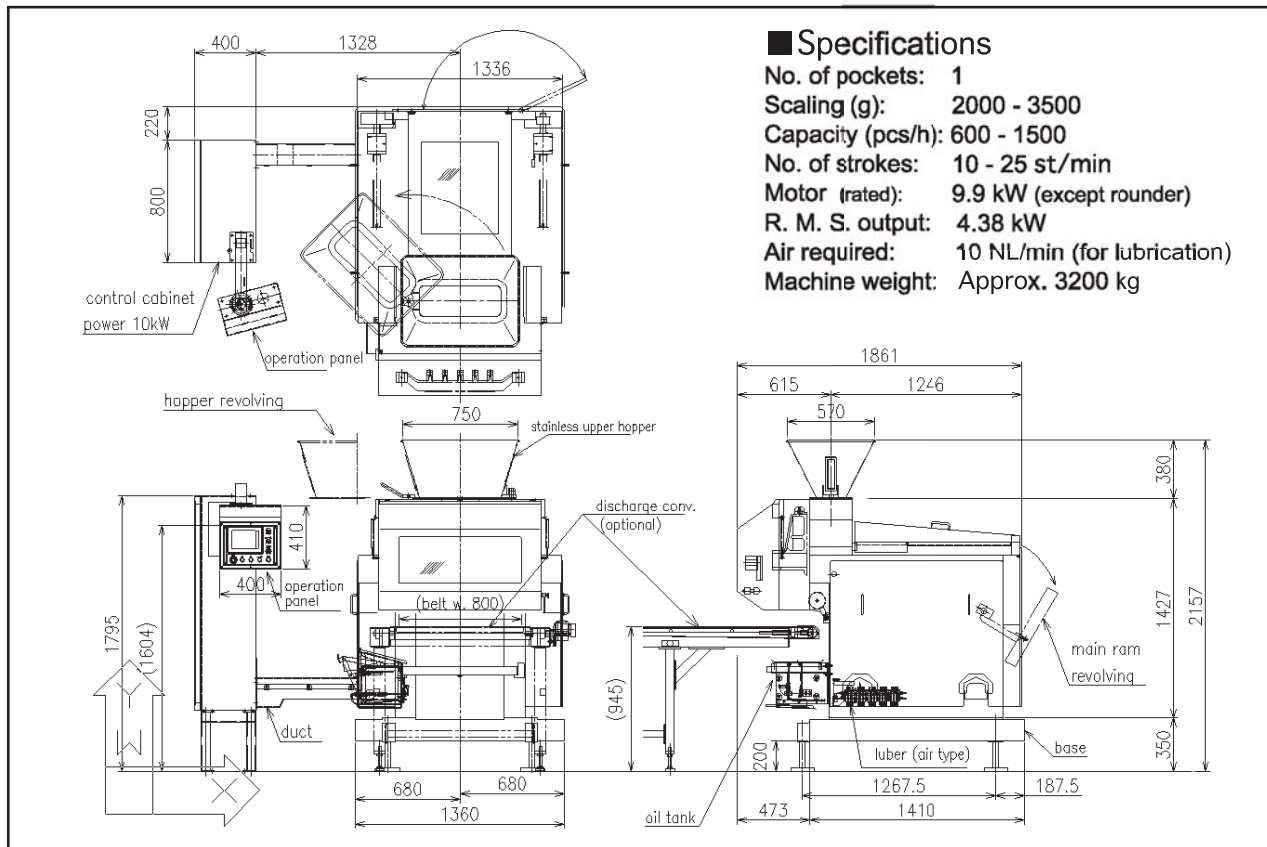

Specifications

No. of pockets:	1
Scaling (g):	2000 - 3500
Capacity (pcs/h):	600 - 1500
No. of strokes:	10 - 25 st/min
Motor (rated):	9.9 kW (except rounder)
R. M. S. output:	4.38 kW
Air required:	10 NL/min (for lubrication)
Machine weight:	Approx. 3200 kg

EASY CLEANING

See-through exterior cover.
Components move to cleaning position by one touch on touch screen.

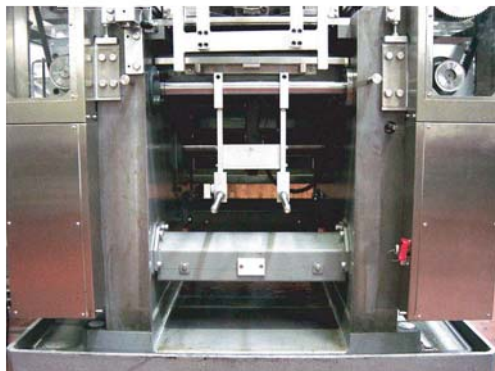

Dough chamber perfectly separated from driving section.
Mechanical units mostly located outside of frame. Easily accessible.

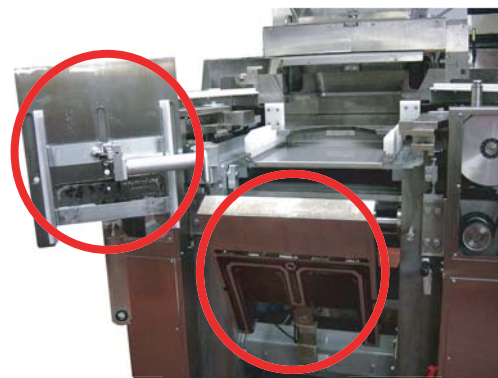

Equipped with cleaning aid device for main ram and knife.
Even flip side easily cleaned.

OSHIKIRI MACHINERY LTD. <http://www.oshikiri.com/>

1-15-14 Ohmori-Nishi, Ohta-ku, Tokyo 143-0015 Japan
Phone: 03-3764-9176 Fax: 03-3764-1564 E-mail: intl@oshikiri.com

Oshikiri Corporation of America
10425 Drummond Road, Philadelphia, Pennsylvania 19154-3898
Phone: 215-637-6005 Fax: 215-637-6041 E-mail: oshikiri-production@msn.com



Oshikiri's quality system is ISO9001:2000 certified. Oshikiri Corp. of America is excluded.