

DOUGH CENTERING UNIT

HIT THE TARGET POSITION

OSHIKIRI is in full pursuit of eye technology



FEATURES

- Positioning can be made at high speed
- No effect on the color of products
- Fuzzy control technology was used

APPLICABLE SAMPLE

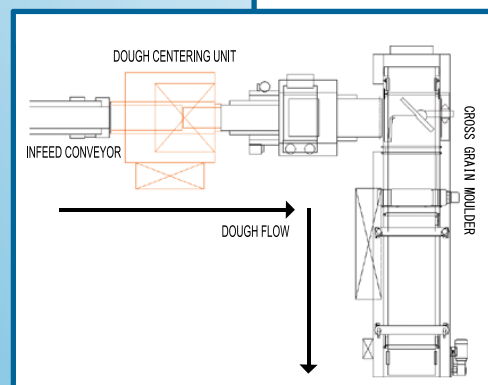
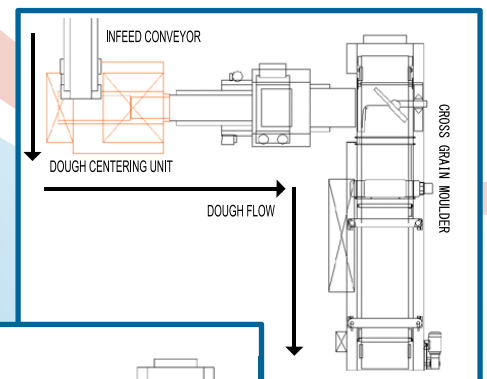

OSHIKIRI

DOUGH CENTERING UNIT

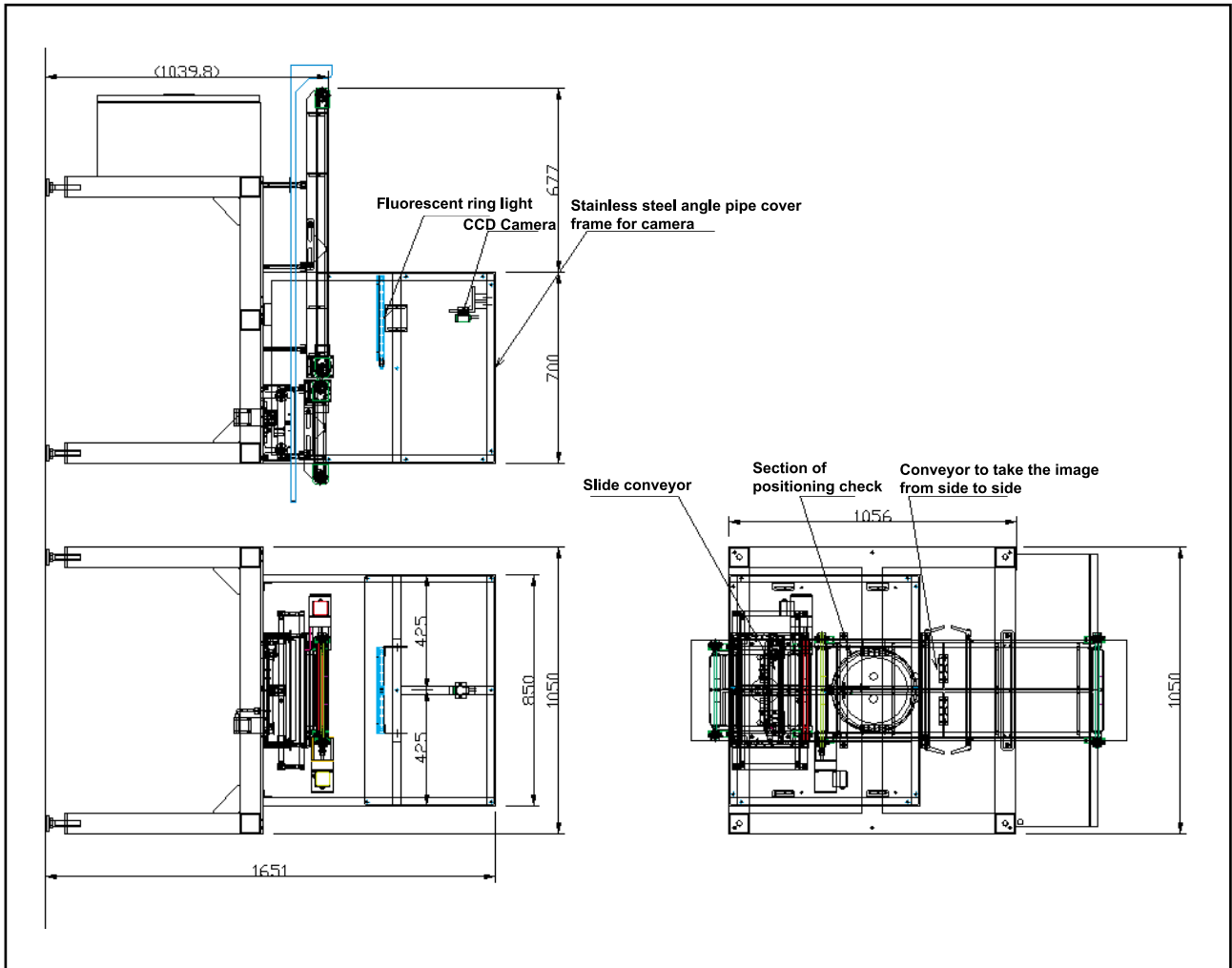

SPECIFICATIONS

CAPACITY	3000pcs/h		
CONTROL RANGE	± 50 mm		
MOTOR	AC200V 3Phases 1kW		
MACHINE DIMENSION	W 1050mm	L 1450mm	H 1651mm
MACHINE WEIGHT	500kg		

Note) Specifications and dimensions may be subject to change without prior notice.

Note) Supply voltage is in accordance with the one in the country machine is used.

Transformer might be needed according to the specifications.

OSHIKIRI MACHINERY LTD. <https://www.oshikiri.com/>

4, Kirihara-cho, Fujisawa-shi, Kanagawa, 252-0811 Japan
 Phone: 0466-44-6184 Fax: 0466-44-6187 E-mail: intl@oshikiri.com

Oshikiri Corporation of America
 10425 Drummond Road, Philadelphia, Pennsylvania 19154-3898
 Phone: 215-637-6005 Fax: 215-637-6041 E-mail: oshikiri-production@msn.com